

MemoTrans

Compact multiparameter transmitter

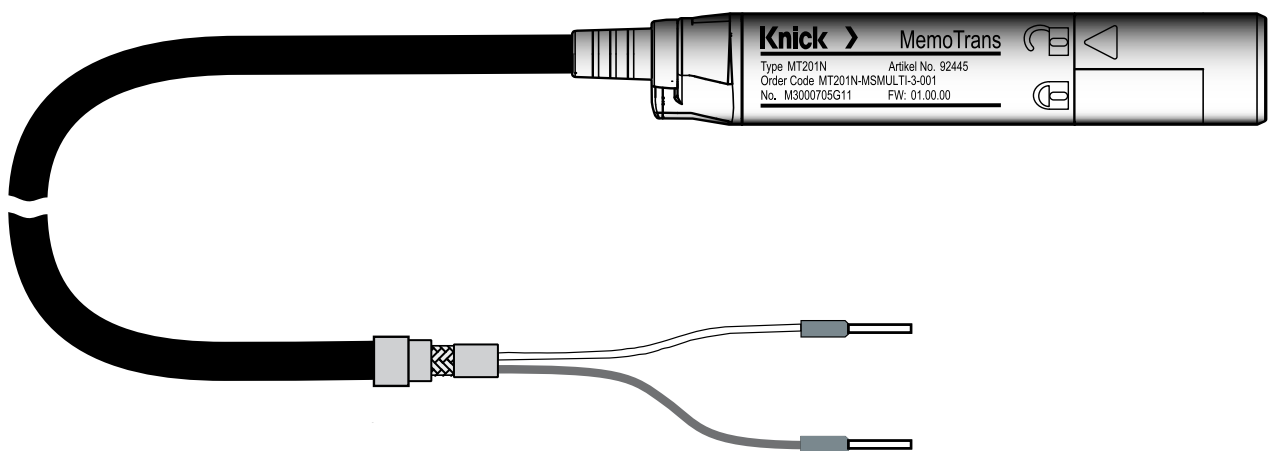

Read before installation.
Keep for future use.



Supplemental Directives

READ AND SAVE THIS DOCUMENT FOR FUTURE REFERENCE. BEFORE ATTEMPTING TO ASSEMBLE, INSTALL, OPERATE OR MAINTAIN THE PRODUCT, PLEASE ENSURE A COMPLETE UNDERSTANDING OF THE INSTRUCTIONS AND RISKS DESCRIBED HEREIN. ALWAYS OBSERVE ALL SAFETY INFORMATION. FAILURE TO COMPLY WITH INSTRUCTIONS IN THIS DOCUMENT COULD RESULT IN SERIOUS INJURY AND/OR PROPERTY DAMAGE. THIS DOCUMENT IS SUBJECT TO CHANGE WITHOUT NOTICE.



These supplemental directives explain how safety information is laid out in this document and what content it covers.

Safety Chapter

This document's safety chapter is designed to give the reader a basic understanding of safety. It illustrates general hazards and gives strategies on how to avoid them.

Warnings

This document uses the following warnings to indicate hazardous situations:

Symbol	Category	Meaning	Remark
	WARNING	Designates a situation that can lead to death or serious (irreversible) injury.	The warnings contain information on how to avoid the hazard.
	CAUTION	Designates a situation that can lead to slight or moderate (reversible) injury.	
<i>None</i>	NOTICE	Designates a situation that can lead to property or environmental damage.	

Symbols Used in this Document





Symbol	Meaning
	Reference to additional information
	Interim or final result in instructions for action
	Sequence of figures attached to an instruction for action
	Item number in a figure
(1)	Item number in text

Table of Contents

1 Basic Safety Instructions	5
1.1 Personnel Requirements.....	5
1.2 Intended Use.....	5
1.3 Symbols and Markings on the Product	5
1.4 Occupational Safety	5
1.5 Operational Safety	6
2 Product Description	7
2.1 Product Design.....	7
3 Incoming Acceptance and Product Identification	8
3.1 Incoming Acceptance.....	8
3.2 Product Identification.....	8
3.3 Package Contents.....	8
3.4 Certificates and Approvals	8
4 Installation	9
4.1 Dimensions.....	9
5 Electrical Connection	10
5.1 Connection	10
5.2 Post-Connection Check.....	10
6 Operating Options	11
6.1 Overview of Operating Options.....	11
6.2 Structure and Function of the Operating Menu	11
7 System Integration	12
7.1 Integrating the Compact Transmitter into the System	12
8 Commissioning	13
8.1 Preparatory Steps.....	13
8.2 Function Check.....	13
8.3 Date and Time	15
8.4 Configuring the Measuring Device.....	15
8.5 Configuration Management.....	22
9 Operation	23
9.1 Reading Measured Values	23
9.2 Adapting the Measuring Device to the Process Conditions	24
10 Calibration	25
10.1 pH Sensor	25
10.2 ORP Sensor.....	25
10.3 Combo Sensor (pH/ORP)	25
10.4 Conductivity Sensor	25
10.5 Oxygen Sensor	25

11 Diagnostics and Troubleshooting	26
11.1 Diagnostic Information via LED.....	26
11.2 Adapting the Diagnostic Information.....	26
11.3 Adapting Sensor Diagnostic Information.....	27
11.4 Simulation	35
11.5 Diagnostic List	36
11.6 Event Logbook	46
11.7 Resetting the Measuring Device.....	46
11.8 Device Information	46
12 Maintenance	47
12.1 Remarks.....	47
12.2 Maintenance Tasks	47
13 Repair	48
13.1 General Notes	48
13.2 Return	48
13.3 Disposal.....	48
14 Specifications.....	49
15 Power Supply	52
Index.....	53

1 Basic Safety Instructions

1.1 Personnel Requirements

- Installation, commissioning, operation, and maintenance of the measuring system may be carried out only by specially trained technical personnel.
- The technical personnel must be authorized by the system operator to carry out the specified activities.
- The electrical connection may be performed only by a licensed electrician.
- The technical personnel must have read and understood this User Manual and must follow the instructions contained therein.
- Faults at the measuring point may only be rectified by authorized and specially trained personnel.

Note: Repairs not described in the User Manual provided must be carried out only directly at the manufacturer's site or by the service organization.

1.2 Intended Use

The device is a transmitter for connecting digital sensors with Memosens technology. It is preset for sensor parameters and a measuring range span with 4 ... 20 mA communication.

The device is designed for use in the following industries:

- Life science
- Chemistry
- Water and wastewater
- Food and beverage
- Power plants
- Other industrial applications

1.3 Symbols and Markings on the Product

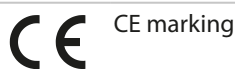

Special conditions and the product's possible danger points. Read the user manual, observe the specifications, and follow the instructions in the safety guide.



Reminder to read the documentation.

1.4 Occupational Safety

As the user, you are responsible for complying with the following safety conditions:

- Installation guidelines
- Local standards and regulations
- Regulations for explosion protection

Electromagnetic Compatibility

- The product has been tested for electromagnetic compatibility in accordance with the applicable European standards for industrial applications.
- The electromagnetic compatibility indicated applies only to a product that has been connected in accordance with this User Manual.

1.5 Operational Safety

Before commissioning the entire measuring point:

01. Verify that all connections are correct.
02. Ensure that electrical cables and hose connections are undamaged.
03. Do not operate damaged products, and protect them against unintentional operation.
04. Label damaged products as defective.

During operation:

- If faults cannot be rectified: Products must be taken out of service and protected against unintentional operation.

⚠ CAUTION! Cleaning not switched off during calibration or maintenance activities

Risk of injury due to medium or cleaning agent

- If a cleaning system is connected, switch it off before removing a sensor from the medium.
- If you wish to check the cleaning function and have therefore not switched off the cleaning system, wear protective clothing, goggles, and gloves or take other appropriate measures.

2 Product Description

2.1 Product Design

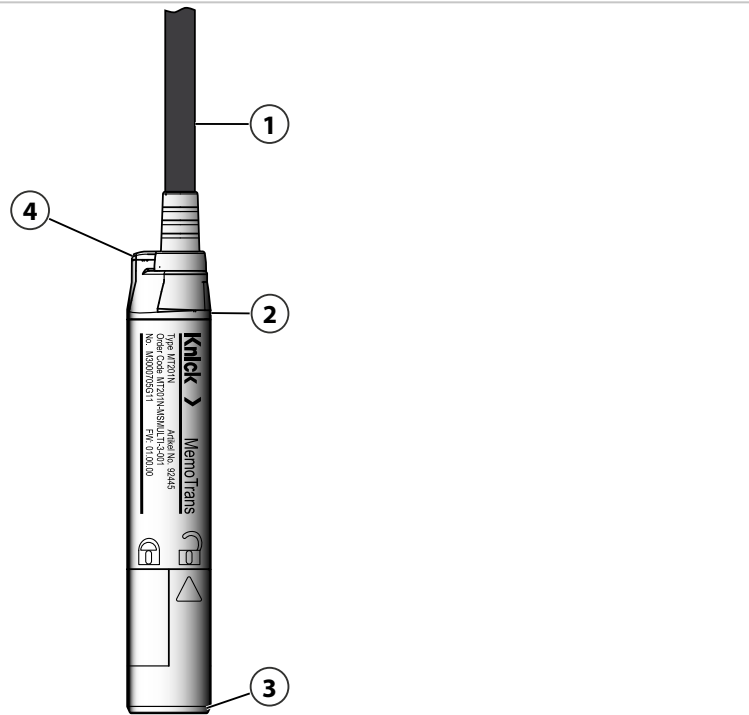

1 Cable	3 Memosens connection
2 Housing	4 LED, for optical signaling of operating statuses of measuring point

2.1.1 Measuring Parameters

The transmitter is designed for Memosens sensors with inductive connector:

- pH, ORP, pH/ORP combo sensors
- Contacting conductivity
- Oxygen, amperometric

3 Incoming Acceptance and Product Identification

3.1 Incoming Acceptance

01. Verify that the packaging is undamaged.
 - ✓ Notify the supplier of any damage to the packaging. Keep the damaged packaging until the issue has been resolved.
02. Verify that the contents are undamaged.
 - ✓ Notify the supplier of any damage to the delivery contents. Keep the damaged goods until the issue has been resolved.
03. Check that the delivery is complete and nothing is missing.
 - ✓ Compare the shipping documents with your order.
04. Pack the product for storage and transportation in such a way that it is protected against impact and moisture.
 - ✓ The original packaging offers the best protection. Make sure to comply with the permitted ambient conditions.

If you have any questions, please contact your supplier or local sales center.

3.2 Product Identification

3.2.1 Nameplate

The nameplate contains the following information:

- Manufacturer identification
- Serial number
- Safety information and warnings
- Ex labeling on hazardous area versions
- Certificate information

Compare the data on the nameplate with your order.

3.3 Package Contents

The package contents include:

- 2-wire compact transmitter
- Installation Guide

If you have any questions, please contact your supplier or local sales center.

3.4 Certificates and Approvals

3.4.1 CE Mark

The product meets the requirements of the harmonized European standards. As such, it complies with the legal specifications of the EU directives. The manufacturer confirms successful testing of the product by affixing to it the CE mark.

4 Installation

4.1 Dimensions

Note: All dimensions are given in millimeters [inches].

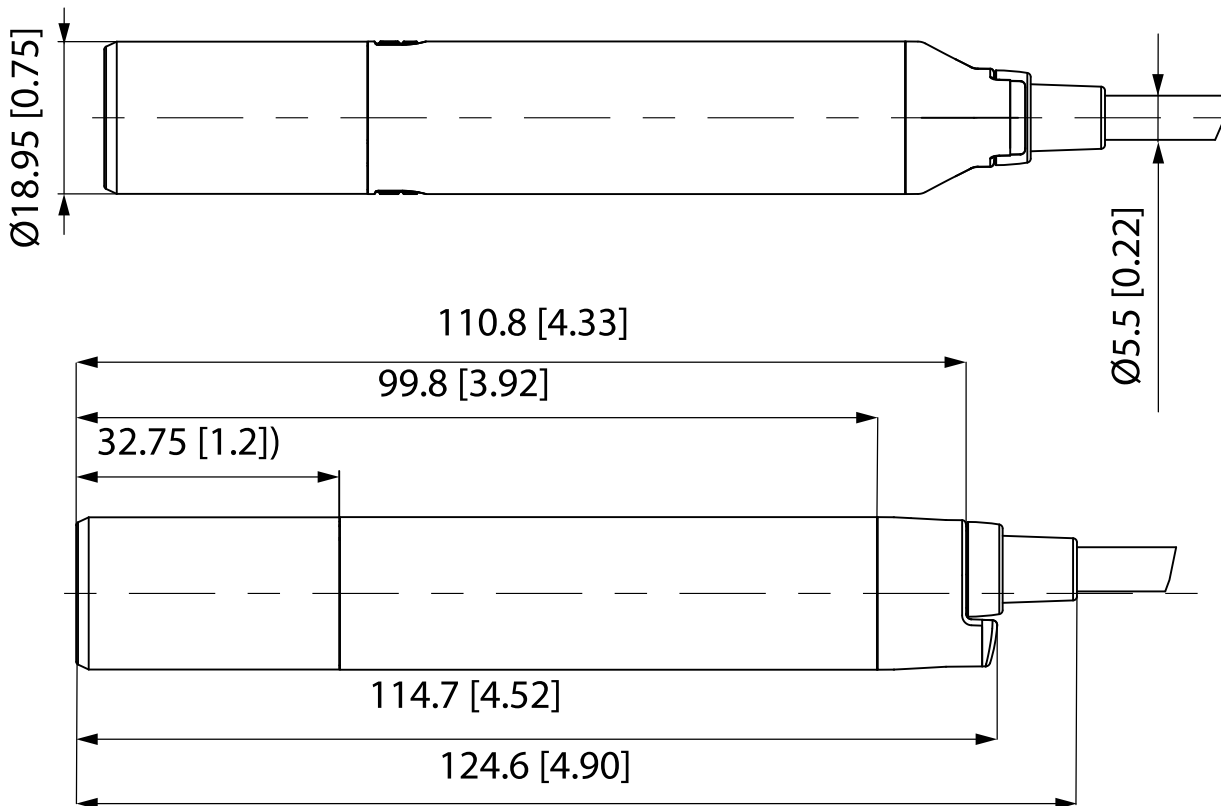

5 Electrical Connection

⚠ WARNING! Device is live Incorrect connection may result in injury or death.

- The electrical connection may be performed only by a licensed electrician.
- The licensed electrician must have read and understood this User Manual and must follow the instructions contained therein.
- Prior to commencing connection work, ensure that no voltage is present on any cable.

5.1 Connection

Supply voltage	12,6 ... 30 V DC (with a fault current > 20 mA)
	14 ... 30 V DC (with a fault current set to 3.6 mA)
Cable length	3 m (10 ft)
	7 m (23 ft)
	15 m (46 ft)
Signal output	4 ... 20 mA HART
Signal on alarm	3.6 or 23 mA

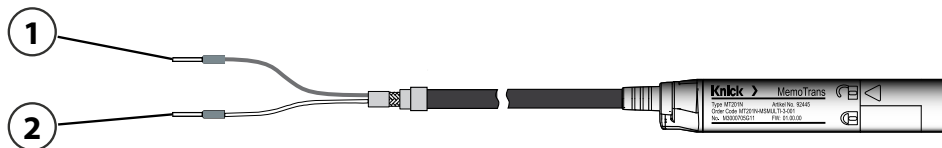

1 BU +

2 WH -

Pull the previously cut insulation piece off the shielding braid and ground the braid appropriately. The grounding cable is not a part of the package contents and must be provided by the customer.

- Connect ferrules as specified in the table:

Cable	Function
Blue (BU)	4 ... 20 mA+
White (WH)	4 ... 20 mA-

5.2 Post-Connection Check

⚠ WARNING! Connection errors. The safety of people and of the measuring point is endangered. The manufacturer does not accept any responsibility for errors that result from failure to comply with the instructions in this manual.

Put the device into operation only if you can answer yes to all the following questions.

Electrical connection:

- Is the device or cable undamaged (visual inspection)?
- Do the mounted cables have adequate strain relief?
- Are the cables routed without loops or crossovers?
- Does the supply voltage match the specifications on the nameplate?
- No reverse polarity, is terminal assignment correct?

6 Operating Options

6.1 Overview of Operating Options

Operation and settings via:

- PLC control station (via HART)

6.2 Structure and Function of the Operating Menu

In the Home view, the current measured values are displayed along with the device information (tag, serial number, firmware version, order code).

The device is operated via four main menus:

- Guidance
- Diagnostics
- Application
- System

Menu	Function
Guidance	Contains functions involving a self-contained sequence of activities, e.g., for calibration (= wizard).
Diagnostics	Contains information regarding operation, diagnostics, and troubleshooting, as well as configuration of the diagnostic behavior.
Application	Sensor data for specific optimization and for detailed process adjustment. Adjustment of measuring point to the application.
System	These menus contain parameters for configuring the overall system.

7 System Integration

7.1 Integrating the Compact Transmitter into the System

For measured value transmission:

- 4 ... 20 mA
- HART

7.1.1 HART

In addition to the analog 4 ... 20 mA signal, further measured values and the status of the device can be transmitted digitally via the HART protocol.

Parameter setting is also possible using an additional control unit and a suitable driver.

Operation is possible via various operating devices (handhelds).

8 Commissioning

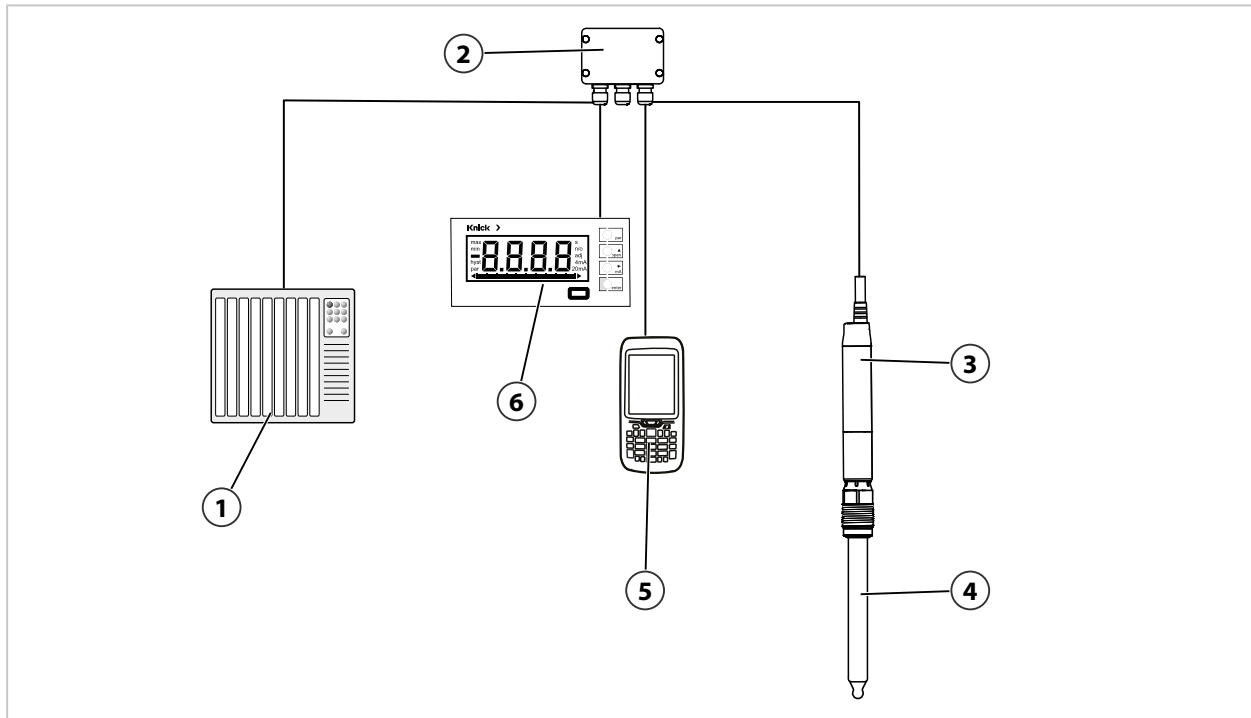

1 PLC (programmable logic controller)	4 Sensor
2 Junction box	5 Option: HART control unit
3 MemoTrans	6 Digital panel meter

8.1 Preparatory Steps

01. Connect the device.

- ✓ The device starts up and transmits the measured value as a current value.

8.2 Function Check

⚠ WARNING! Incorrect connection, incorrect supply voltage

Safety risks for staff and device malfunctions!

- Check that all connections have been established correctly in accordance with the wiring diagram.
- Ensure that the supply voltage matches the voltage indicated on the nameplate.

Familiarize yourself with the operation of the device before it is first switched on. In particular, please read the "Basic Safety Instructions" chapter. After power-on, the device performs a self-test and then goes to the measuring mode.

8.2.1 LED Display

LED messages signal the status of the device and sensor.

LED behavior	Status
Green Blinks quickly	Everything OK. Device starting up.
Green Blinks twice	Everything OK. Read out Memosens sensor information from sensor to transmitter (sensor type, calibration data, etc.)
Green Blinks slowly	Everything OK. Sensor and device OK and functioning correctly.
Green Blinks quickly three times	Everything OK. Measured value at PLC in automatic HOLD. If the "Sensor replacement alarm delay" is exceeded, the device transmits a signal on alarm. The automatic hold is set to 30 seconds but can be configured to suit the customer's needs.
Red Blinks quickly	Failure of device or sensor Error status signal as per NAMUR NE107.
Red, green Blinks three times red alternating with three times green	Squawk Squawk is signaled briefly while the connection is established. This makes it possible to locate the device more quickly, e.g., when several devices are installed, you can see which one the connection is established with.

8.3 Date and Time

Configure the date and time in [System](#) ▶ [Date](#) ▶ [Time](#).

Note: The date and time function runs only while the device is supplied with power. They must be reset if the power supply is interrupted.

8.4 Configuring the Measuring Device

Path: [Application](#) ▶ [Units](#)

Function	Options	Info
Temperature unit	Selection <ul style="list-style-type: none"> • °C • °F • K Factory setting <ul style="list-style-type: none"> • °C 	
Conductivity unit	Selection <ul style="list-style-type: none"> • µS/cm • mS/cm • S/cm • µS/m • mS/m • S/m Factory setting <ul style="list-style-type: none"> mS/cm 	To be selected for conductivity.
Concentration (liquid) unit	Selection <ul style="list-style-type: none"> • mg/l • µg/l • ppm • ppb 	To be selected for oxygen.
Concentration (gaseous) unit	Selection <ul style="list-style-type: none"> • %vol • ppm-Vol 	

8.4.1 Changing the Tag Number

You can change the tag number here:

[System](#) ▶ [Device Management](#) ▶ [Tag Number](#)

8.4.2 Configuring the Sensor

Path: Application

Function	Options	Info
Sensor		Sensor-dependent settings
Sensor type		Display the sensor type
Order code		Order code of sensor
	ORP	Display % value
		Display ORP as percentage (pH/ORP combo sensors only)
Damping		The damping causes a floating average curve of the measured values over the time specified.
	Damping pH, Damping ORP, Damping oxygen, Damping conductivity	0 ... 60 s Factory setting 0 s
		These functions determine the damping of the primary value of the connected sensor.
	Damping temperature	0 ... 60 s Factory setting 0 s
		These functions determine the damping of the integrated temperature sensor.
TAG control		
	Sensor check	Selection • Off • TAG • Group Factory setting Off
	Group	Range: 0 ... 65535
Extended setup		
Conductivity:		
Current cell constant	Read only	Value currently saved in the sensor.
Compensation	Selection • None • Linear • NaCl (IEC 746-3) • Water ISO7888 (20 °C) • Water ISO7888 (25 °C) • Ultrapure water (NaCl) • Ultrapure water (HCl) Factory setting Linear	Various methods are available to compensate for the temperature dependency. Depending on your process, decide which type of compensation you want to use. Alternatively, you can also select None and thus measure uncompensated conductivity. Compensation for ultrapure water is only available with contacting sensors.
Meas. ref. temp.	-5.0 ... 100.0 °C (23.0 ... 212.0 °F) Factory setting 25.0 °C (77.0 °F)	Reference temperature for calculating the temperature-compensated conductivity
Factor alpha	0.000 ... 20.000 %/K Factory setting 2.100 %/K	Enter the conductivity coefficient of your process medium

pH:

Temp. compensation	Selection <ul style="list-style-type: none"> • Off • Automatic • Manual Factory setting Automatic	Decide how you want to compensate the medium temperature: <ul style="list-style-type: none"> • Automatically using the temperature sensor of your sensor (ATC) • Manually by entering the medium temperature • Not at all
Medium comp.	Selection <ul style="list-style-type: none"> • Off • Two-point calibration Factory setting Off	Take a sample from the medium and determine its pH value at different temperatures in the lab.
Offset	-18.00 ... 18.00 pH -100 ... 100 mg/l Factory setting 0.00 pH 0.00 mg/l	The offset compensates for a difference between a laboratory measurement and an online measurement which is caused by interference ions. Enter this value manually. If you are using a compensation electrode, keep the offset at zero.
Internal buffer	pH 0 ... 14 Factory setting pH 7.00	Only change the value if you are using a sensor with an internal buffer other than pH 7.

Oxygen:

Medium pressure	Selection <ul style="list-style-type: none"> • Process pressure • Air pressure • Altitude Factory setting Air pressure	Press Measured value to connect a pressure measured value via a fieldbus input or a current input. This measured value is then used for medium pressure compensation. For the other types of compensation, specify a compensation value for the measurement in each case. <ul style="list-style-type: none"> • Specify either the altitude (-300 ... 4000 m), the process pressure (500 ... 9999 hPa), or the air pressure (500 ... 1200 hPa) of the measuring point. The pressure used during the calibration is also displayed for information purposes. You can change this pressure in: Calibration settings ▶ Ambient conditions ▶ Medium pressure
Salinity	Selection <ul style="list-style-type: none"> • Fixed value • Measured value Factory setting Fixed value (0.0 g/kg)	
Diagnostic settings		Sensor diagnostic settings → <i>Adapting Sensor Diagnostic Information, p. 27</i>

Calibration Settings

Path: Application ▶ Sensor ▶ Calibration settings

Function	Options	Info
pH, ORP, pH/ORP, ISFET		
Stability criterion		Once the stability criterion is met, the measured value is displayed in mV.
Delta mV	1 ... 10 mV Factory setting 1 mV	Measured value depending on connected sensor
Duration	10 ... 60 s Factory setting 20 s	
Temp. compensation (pH only)	Selection <ul style="list-style-type: none"> Off Automatic Manual Factory setting Fixed	Decide how you want to compensate the buffer temperature: <ul style="list-style-type: none"> Automatically using the temperature sensor of your sensor (ATC). Manually by entering the medium temperature.
Buffer recognition	Selection <ul style="list-style-type: none"> Fixed Automatic (pH or pH/ORP combo sensor only) Manual Factory setting	Fixed: You choose values from a list. The list depends on the setting for Buffer manufacturer . Automatic: The device recognizes the buffer automatically. The recognition depends on the setting for Buffer manufacturer . NOTICE! As their zero point is offset, enamel pH sensors cannot be calibrated and adjusted with automatic buffer recognition. Manual: You enter any two buffer values. These must differ in terms of their pH value.
Buffer manufacturer	Selection <ul style="list-style-type: none"> Endress+Hauser Ingold/Mettler DIN 19266 DIN 19267 Merck/Riedel Hamilton Factory setting Endress+Hauser	Temperature tables are stored internally in the unit for the following pH values: Endress+Hauser 2.00 / 4.00 / 7.00 / (9.00) / 9.22 / 10.00 / 12.00 Ingold/Mettler 2.00 / 4.01 / 7.00 / 9.21 DIN 19266 1.68 / 4.01 / 6.86 / 9.18 DIN 19267 1.09 / 4.65 / 6.79 / 9.23 / 12.75 Merck/Riedel 2.00 / 4.01 / 6.98 / 8.95 / 12.00 Hamilton 1.09 / 1.68 / 2.00 / 3.06 / 4.01 / 5.00 / 6.00 / 7.00 / 8.00 / 9.21 / 10.01 / 11.00 / 12.00
Calibration buffer 1 ... 2		The possible options and the factory setting depend on the Buffer manufacturer .

Function	Options	Info
Oxygen:		
Stability criteria		
Delta signal	0.1 ... 2.0% Factory setting 0.2 %	Permitted measured value fluctuation during calibration. Referenced to the raw value in nA in the case of amperometric sensors.
Delta temperature	0.10 ... 2.00 K Factory setting 0.50 K	Permitted thermal fluctuation during calibration.
Duration	5 ... 60 s Factory setting 20 s	Timeframe within which the permitted measured value variation may not be exceeded
Ambient conditions		
Medium pressure	Selection <ul style="list-style-type: none"> • Process pressure • Air pressure • Altitude • As during measurement (measured value) Factory setting Air pressure 1013 bar	
Process pressure Medium pressure = process pressure	500 ... 1200 hPa Factory setting 1013 hPa	Enter the altitude or the average air pressure of the place of calibration (mutually dependent values). If you specify the altitude, the average air pressure is calculated from the barometric altitude formula and vice versa. If you are compensating using the process pressure, enter the pressure in your calibration medium here. The pressure is then independent of the altitude.
Air pressure Medium pressure = air pressure	500 ... 1200 hPa Factory setting 1013 hPa	
Altitude Medium pressure = altitude	-300 ... 4000 m Factory setting 0 m	
Rel. hum. (air variable)	0 ... 100 %	
Calibration monitoring (calibration timer)		
Function	Selection <ul style="list-style-type: none"> • Off (during operation, during sensor connection) Factory setting Off	
Calibration check: calibration validity		The function checks whether the calibration of a sensor is still valid. Example: You install a precalibrated sensor. The function checks how long ago the sensor was last calibrated. A diagnostics message is displayed if the time since the last calibration is longer than specified by the predefined warning and alarm limit.

Function	Options	Info
Warning limit	1 ... 20,000 h Factory setting 800 h	Warning and alarm limits mutually influence each other's possible adjustable range.
Alarm limit	1 ... 20,000 h Factory setting 1000 h	Warning and alarm limits mutually influence each other's possible adjustable range.

8.4.3 Current Output

Path: [Application](#) ▶ [Current output](#)

Function	Options	Info
Current output		
Output value	<p>pH, ISFET, ORP, and pH/ORP options</p> <ul style="list-style-type: none"> • pH • Raw value pH • Impedance glass • Impedance reference • rH • ISFET leakage current • ORP mV • ORP % • Temperature <p>Oxygen options</p> <ul style="list-style-type: none"> • Partial pressure • % saturation • Conc. (liquid) unit • Conc. (gaseous) unit • Raw value nA • Temperature <p>Conductivity options</p> <ul style="list-style-type: none"> • Conductivity • Resistance • Raw value (cond. uncomp.) • Temperature 	Depending on connected sensor
Range lower value (4 mA)	The unit depends on the sensor configured.	Enter the measuring range. The lower and upper range values are assigned to the 4 mA value and the 20 mA value respectively. The system uses the engineering unit which you entered beforehand.
Range upper value (20 mA)		

8.4.4 HART

Path: [Application](#) ▶ [HART](#) ▶ [Output status](#)

Function	Options	Info
Bus address	0 ... 63 Factory setting 0	Enter the bus address Address 0 ... 63 Multidrop mode
PV value	Choose from Current output ▶ Output value	Primary process value
Partial pressure		Partial pressure dependence for oxygen

Function	Options	Info
SV value TV value QV value	<p>pH, ISFET, ORP, and pH/ORP units</p> <ul style="list-style-type: none"> • pH • Raw value pH, mV(pH) • Glass impedance • Impedance reference • rH • ISFET leakage current • ORP mV • ORP % • Temperature <p>Oxygen units</p> <ul style="list-style-type: none"> • Partial pressure • % saturation • Concentration (liquid) unit • Conc. (gaseous) unit • Raw value nA • Temperature <p>Conductivity units</p> <ul style="list-style-type: none"> • Conductivity • Resistance • Raw value (cond. uncomp.) • Temperature 	<p>Protocol-specific data, dynamic variables of HART communication.</p> <p>SV = secondary TV = tertiary QV = quaternary</p>

8.4.5 Hold

The hold state is a safe condition during configuration and calibration.

Path: System ▶ Hold

Function	Options	Info
Hold release time	<p>0... 600 s</p> <p>Factory setting</p> <p>0 s</p>	The hold status is maintained for the duration of the delay time when you switch to the measuring mode.
Hold behavior	<p>Selection</p> <ul style="list-style-type: none"> • Ignore • Freeze • Fixed value <p>Factory setting</p> <p>Freeze</p>	
Hold current	<p>3.6... 23 mA</p> <p>Factory setting</p> <p>0 s</p>	Hold current setting only possible if hold behavior selection is "Fixed value".
Manual hold	<p>Selection</p> <ul style="list-style-type: none"> • Off • On <p>Factory setting</p> <p>Off</p>	<p>On: You can use this function to set the channel manually to "Hold".</p> <p>Off: No channel-specific hold</p>

Function	Options	Info
Calibration hold	Selection <ul style="list-style-type: none"> • No • Yes Factory setting Yes	During calibration, the output signal is set to "Hold".

8.5 Configuration Management

Display the following configurations:

For general system information

Path: System ▶ System information

For general HART information

Path: Application ▶ HART

For general sensor information

Path: System ▶ Sensor information

- General information
- Extreme values
- Sensor operation
- Sensor specifications

For general calibration information

Path: System

- Temperature adjustment
- Primary value

9 Operation

9.1 Reading Measured Values

The display of the primary values is dependent on the connected sensor.

Function

Measured values

For pH glass, ISFET, ORP, or pH/ORP combo sensors:

- pH
- Raw value pH
- Impedance glass
- Impedance reference
- ORP mV
- ORP %
- rH
- Temperature

For oxygen sensors:

- Partial pressure
- % saturation
- Conc. (liquid) unit
- Conc. (gaseous)
- Raw value nA
- Raw value μ s
- Temperature

For conductivity sensors:

- Conductivity
- Resistance
- Raw value (cond. uncomp.)
- Temperature
- Current output

Data relating to the transmitter:

- Tag number
- Device type
- Serial number
- Firmware version
- Order code

9.1.1 Changing the Parameters

The device functions according to the plug & play principle of Memosens technology. However, to ensure that the settings of the previous sensor type do not get lost, the new sensor type must be selected in the software.

Path: [Guidance](#) ▶ [Measurement parameter](#)

Function	Options	Info
Measurement parameter	Selection <ul style="list-style-type: none"> • pH, ORP, pH/ORP • Dissolved oxygen • Conductivity 	Select the parameters supported by the device.

9.2 Adapting the Measuring Device to the Process Conditions

Medium Compensation (in the Process) for Oxygen

Path: [Application](#) ▶ [Sensor](#) ▶ [Extended setup](#)

Function	Options	Info
Medium pressure	Selection <ul style="list-style-type: none"> • Process pressure • Air pressure • Altitude 	Specify altitude (-300 ... 4000 m), process pressure (500 ... 9999 hPa), or air pressure (500 ... 1200 hPa) of measuring point.
Salinity	0 ... 40 g/kg Factory setting 0 g/kg	The influence of salt content on oxygen measurement is compensated with this function. Example: sea water measurement as per Copenhagen Standard (30 g/kg).

10 Calibration

10.1 pH Sensor

1-point calibration	The measured value is adjusted with a known reference value (buffer solution or known medium). The zero offset is stored in the sensor.
2-point calibration	Calibration adjustment of zero point and slope of the sensor with 2 buffers.
Sampling	The measured value is adjusted with a known reference value (buffer solution or known medium). The zero offset is stored in the sensor.

10.2 ORP Sensor

1-point calibration	Calibration (mV): The measured value is adjusted with a known reference value (buffer solution or known medium). The zero offset is stored in the sensor.
ORP % assignment	The measured value in mV is converted to a % concentration using a conversion table.

10.3 Combo Sensor (pH/ORP)

pH	
1-point calibration	The measured value is adjusted with a known reference value (buffer solution or known medium). The zero offset is stored in the sensor.
2-point calibration	Calibration adjustment of zero point and slope of the sensor with 2 buffers.
Sampling	The measured value is adjusted with a known reference value (buffer solution or known medium). The zero offset is stored in the sensor.
ORP	
1-point calibration (mV)	1-point calibration is used if only the deviation from a reference value is to be detected rather than an absolute value.
ORP % assignment	The measured value in mV is converted to a % concentration using a conversion table.

10.4 Conductivity Sensor

Cell constant	The electrical resistance or its reciprocal, the conductance G , is calculated according to Ohm's law. Using the cell constant k determined by the sensor geometry, the specific conductivity κ is determined from the conductance.
---------------	--

10.5 Oxygen Sensor

Air 100 % rH	The sensor signal in the presence of oxygen is determined by calibrating the sensor in air saturated with water vapor. For this model to work properly, the sensor to be calibrated must be near a water surface or, for example, in the gas-filled space of a vessel partially filled with water.
H ₂ O air saturated	The sensor signal in the presence of oxygen is determined by calibrating the sensor in water saturated with air.
Air variable	This calibration model is for all applications in which air pressure and air humidity in the environment of the sensor do not correspond to the aforementioned atmospheric standard values, but are nevertheless known. Both values can be specified here.
Sampling	The measured value is adjusted with a known reference value.

11 Diagnostics and Troubleshooting

11.1 Diagnostic Information via LED

See LED display in the Commissioning chapter. → *LED Display, p. 14*

11.2 Adapting the Diagnostic Information

Path: Diagnostics ▶ Diagnostic settings

Function	Options	Info
Sensor change alarm delay	0 ... 180 s Factory setting 30 s	Sensor HOLD
Fault current	3.6 ... 23.0 mA Factory setting 3.6 s	Possible range of fault current.
LED shows NAMUR status signal	Selection <ul style="list-style-type: none"> • Off • On Factory setting Off	Additional LED signals for diagnostic messages as per NAMUR NE107 categories.
Diagnostics behavior		The list of diagnostic messages displayed. There are device-specific messages, and messages that depend on what sensor is connected. Select the message to be adapted. Only then can you make the settings for this message.
Status signal		The messages are divided into different error categories in accordance with NAMUR NE107.
Diagnostics behavior	Selection <ul style="list-style-type: none"> • Service • Alarm 	

LED as per NAMUR NE107 categories:

Three rapid green blinks at the start of the message means: Everything OK – but pay attention!

The more red blinks there are at the end of a message, the more critical the diagnostics as per NE107. Continuous red-only blinking means: Error in device or sensor, take action immediately.

LED behavior	Status
Three rapid green blinks and a single rapid red blink	Device or sensor requires maintenance. M status signal as per NAMUR NE107
Three rapid green blinks and two rapid red blinks	Device and sensor are being operated out of specification. S status as per NAMUR NE107
Three rapid green blinks and three rapid red blinks	Device or sensor undergoing function check. C status signal as per NAMUR NE107
Red	Failure of device or sensor
Blinks quickly	F status signal as per NAMUR NE107

11.3 Adapting Sensor Diagnostic Information

This menu branch is used for specifying warning limits, and for defining whether and how diagnostics tools should be used.

11.3.1 Impedance Monitoring

Path: Application ▶ Sensor ▶ Extended setup ▶ Diagnostic settings

Function	Options	Info
Glass impedance		
Upper limit	Selection <ul style="list-style-type: none"> • Off • On Factory setting On	On: The Sensor Check System (SCS) operates with the following settings for the upper warning and alarm limits. Off: Monitoring of the upper warning and alarm limits is switched off.
Upper alarm limit	0 ... 10000 MΩ Factory setting 3000 MΩ	Diagnostics code and associated message text: 124 Sensor glass
Upper warning limit	0 ... 10000 MΩ Factory setting 2500 MΩ	Diagnostics code and associated message text: 125 Sensor glass
Lower limit	Selection <ul style="list-style-type: none"> • Off • On Factory setting Off	On: The Sensor Check System (SCS) operates with the following settings for the lower warning and alarm limits. Off: Monitoring of the lower warning and alarm limits is switched off.
Lower warning limit	0 ... 10000 kΩ Factory setting 100 MΩ	Diagnostics code and associated message text: 123 Sensor glass
Lower alarm limit	0 ... 10000 kΩ Factory setting 0.0 MΩ	Diagnostics code and associated message text: 122 Sensor glass
Reference impedance		
	Selection <ul style="list-style-type: none"> • Off • On Factory setting On	
Upper alarm limit	0 ... 1000 kΩ Factory setting 100.0 MΩ	
Upper warning limit	0 ... 1000 kΩ Factory setting 50.0 MΩ	

11.3.2 ORP Measured Value

Function	Options	Info
Upper limit	Selection <ul style="list-style-type: none"> • Off • On Factory setting On	On: The Sensor Check System (SCS) operates with the following settings for the upper warning and alarm limits. Off: Monitoring of the upper warning and alarm limits is switched off.
Upper alarm limit	-2000 ... 2000 mV Factory setting 1000 mV	
Upper warning limit	-2000 ... 2000 mV Factory setting 900 mV	
Lower limit	Selection <ul style="list-style-type: none"> • Off • On Factory setting Off	On: The Sensor Check System (SCS) operates with the following settings for the lower warning and alarm limits. Off: Monitoring of the lower warning and alarm limits is switched off.
Lower alarm limit	-2000 ... 2000 mV Factory setting 1000 mV	
Lower warning limit	-2000 ... 2000 mV Factory setting 900 mV	

11.3.3 Slope

pH, pH/ORP, oxygen

Path: Application ▶ Sensor ▶ Extended setup ▶ Diagnostic settings

Function	Options	Info
pH		
Slope		The slope characterizes the sensor condition. The greater the deviation from the ideal value (pH), the worse the condition of the sensor.
Warning limit	25.00 ... 65.00 mV/pH Factory setting 55.00 mV/pH	Specify your limit values for slope monitoring. Diagnostics code and associated message text: 509 Sensor calibration
Oxygen		
Upper warning limit	0 ... 200.0 % Factory setting 140.0 %	Diagnostics code and associated message text: 511 Sensor calibration
Lower warning limit	0 ... 200.0 % Factory setting 60.0 %	Diagnostics code and associated message text: 509 Sensor calibration

11.3.4 Delta Slope

pH, pH/ORP, oxygen

Path: Application ▶ Sensor ▶ Extended setup ▶ Diagnostic settings

Function	Options	Info
pH and pH/ORP combo sensors		
Delta slope		The device determines the difference in slope between the last calibration and the penultimate calibration, and issues a warning or an alarm depending on the setting configured. The difference is an indicator for the condition of the sensor. The greater the change, the greater the wear experienced by the pH-sensitive glass membrane as a result of chemical corrosion or abrasion.
Function	Selection <ul style="list-style-type: none"> • Off • On Factory setting Off	Switches the function on or off
Warning limit	0.10 ... 10.00 mV/pH Factory setting 6.00 mV/pH	Specify your limit values for monitoring the slope differential. Diagnostics code and associated message text: 518 Sensor calibration
Oxygen		
Delta slope		The device determines the difference in slope between the last calibration and the penultimate calibration, and issues a warning or an alarm depending on the setting configured. The difference is an indicator for the condition of the sensor. An increasing change indicates the formation of buildup on the sensor diaphragm or electrolyte contamination. Replace the diaphragm and electrolyte as specified in the instructions in the sensor User Manual.

Function	Options	Info
Function	Selection <ul style="list-style-type: none"> • Off • On Factory setting Off	Switches the function on or off
Warning limit	0.0 ... 50.0 % Factory setting 5.0 %	Specify your limit values for monitoring the slope differential. Diagnostics code and associated message text: 518 Sensor calibration

11.3.5 Zero Point and Operating Point

pH, ISFET, Oxygen

Path: [Application](#) ▶ [Sensor](#) ▶ [Extended setup](#) ▶ [Diagnostic settings](#)

Function	Options	Info
pH, pH/ORP		
Zero point (pH glass) Operating point (ISFET)		The zero point or operating point characterizes the condition of the sensor reference. The bigger the deviation from the ideal value (pH 7.00), the poorer the condition. This can be caused by KCl dissolving away or reference contamination, for example.
Upper warning limit	Upper warning limit pH 6.00 ... 12.00 ¹⁾ Upper warning limit 950 mV ²⁾ Factory setting pH 8.00 / 500 mV	Diagnostics code and associated message text: 505 Sensor calibration 515 Sensor calibration ²⁾
Lower warning limit	Lower warning limit pH 2.00 ... 8.00 ¹⁾ Lower warning limit 5000 mV ²⁾ Factory setting pH 8.00 / 500 mV	Diagnostics code and associated message text: 507 Sensor calibration 517 Sensor calibration ²⁾
Oxygen		
Zero point		The zero point corresponds to the sensor signal that is measured in a medium in the absence of oxygen. You can calibrate the zero point in water that is free from oxygen or in high-purity nitrogen. This improves accuracy in the trace range.
Warning limit	0.0 ... 10.0 nA Factory setting 3.0 nA	Specify the limit values for zero point monitoring in your sensor. Diagnostics code and associated message text: 513 Zero warning

¹⁾ pH glass

²⁾ pH ISFET

11.3.6 Delta Zero Point/Operating Point

pH, ISFET, Oxygen

Path: Application ▶ Sensor ▶ Extended setup ▶ Diagnostic settings

Function	Options	Info
pH, pH/ORP, ISFET		
Delta zero point/ operating point (ISFET)		The device determines the difference between the last calibration and the penultimate calibration, and issues a warning or an alarm depending on the setting configured. The difference is an indicator for the condition of the sensor.
Function	Selection <ul style="list-style-type: none"> • Off • On Factory setting Off	Switches the function on or off
Warning limit	pH 0.00 ... 2.00 (pH glass) 1 ... 200 mV (ISFET) Factory setting pH 0.50 / 10 mV	Specify your limit values for monitoring the slope differential. Diagnostics code and associated message text: 520 Sensor calibration (pH glass) 522 Sensor calibration (ISFET)
Oxygen		
Function	Selection <ul style="list-style-type: none"> • Off • On Factory setting Off	Switches the function on or off
Warning limit	0.0 ... 10.0 nA Factory setting 1.0 nA	Specify the limit values for zero point monitoring in your sensor. Diagnostics code and associated message text: 520 Sensor calibration

11.3.7 Operating Hours Limits

Path: Application ▶ Sensor ▶ Extended setup ▶ Diagnostic settings

Function	Options	Info
Limits operating hours		The total operating time of the sensor and its use under extreme conditions is monitored. If the operating time exceeds the defined threshold values, the device issues a corresponding diagnostics message.
Function	Selection <ul style="list-style-type: none"> • Off • On Factory setting Off	On: The operation of the sensor under extreme conditions is monitored, recorded in the sensor, and diagnostics messages are displayed on the controller. Off: No diagnostics messages. However, the time the sensor operates under extreme conditions is recorded in the sensor and can be read in the sensor information in the diagnostics menu.
Operating time	Factory setting Dependent on sensor	
Operating time > 80 °C	Factory setting Dependent on sensor	Diagnostics code and associated message text: 193 Operating time
Operating time > 80 °C < 100 nS/cm	Factory setting Dependent on sensor	Conductivity sensors only

Function	Options	Info
Operating time > 100 °C (pH, ORP, pH/ORP, ISFET only)	Factory setting Dependent on sensor	Diagnostics code and associated message text: 194 Operating time
Operating time > 120 °C (not for pH, ORP)	Factory setting Dependent on sensor	Diagnostics code and associated message text: 195 Operating time
Operating time > 150 °C (not for pH, ORP)	Factory setting Dependent on sensor	Diagnostics code and associated message text: 198 Operating time
Operating time < -300 mV	Factory setting Dependent on sensor	pH or pH/ORP combo sensors only
Operating time > 300 mV	Factory setting Dependent on sensor	pH or pH/ORP combo sensors only
Operating time > 40 °C	Factory setting Dependent on sensor	Oxy sensors only
Operating time > 15 nA	Factory setting Dependent on sensor	Oxy sensors only
Operating time > 50 nA	Factory setting Dependent on sensor	Oxy sensors only

11.3.8 Sterilizations

Path: [Application](#) ▶ [Sensor](#) ▶ [Extended setup](#) ▶ [Diagnostic settings](#)

Function	Options	Info
Sterilizations		The system counts the number of operating hours in which the sensor is exposed to a temperature that is typical for a sterilization. This temperature depends on the sensor.
Function	Selection <ul style="list-style-type: none"> • Off • On Factory setting Off	Switches the function on or off
Warning limit	0... 1000 Factory setting 30	Specify the limit value for the number of sensor sterilizations. Diagnostics code and associated message text: 108 SIP, CIP, autoclaving

Cap Sterilizations (Only Sterilizable Sensors)

Path: [Application](#) ▶ [Sensor](#) ▶ [Extended setup](#) ▶ [Diagnostic settings](#)

Function	Options	Info
No. sterilizations cap		Not displayed for optical oxygen sensors. The sterilization counters in the sensor make a distinction between the sensor and the membrane/fluorescence cap currently used. If this cap is replaced, only the (cap) counter is reset.
Function	Selection <ul style="list-style-type: none"> • Off • On Factory setting Off	Specify how many sterilizations may be performed with a membrane cap before the cap has to be replaced. The number depends heavily on the process and must be determined individually.
Warning limit	1... 100 Factory setting 25	Diagnostics code and associated message text: 109 Sterilization cap

11.3.9 Sensor Condition Check (SCC)

Function	Options	Info
Sensor condition check		<p>Sensor condition check (SCC) monitors the electrode status and the degree of electrode aging. The condition of the electrode is updated after every calibration.</p> <p>The main reasons for a deteriorating electrode status are:</p> <ul style="list-style-type: none"> • Glass membrane blocked or dry • Diaphragm (reference) blocked
Function	Selection <ul style="list-style-type: none"> • Off • On Factory setting Off	Switches the function on or off. Diagnostics code and associated message text: 127 SCC adequate 126 SCC poor

11.3.10 Process Monitoring (PCS)

Path: Application ▶ Sensor ▶ Extended setup ▶ Diagnostic settings

Function	Options	Info
Process monitoring		The process check system (PCS) checks the measuring signal for stagnation. An alarm is triggered if the measuring signal does not change over a specific period (several measured values).
Function	Selection <ul style="list-style-type: none"> • Off • On Factory setting Off	Switches the function on or off
Duration	1 ... 240 min Factory setting 60 min	Once this time has elapsed, the calibration timer diagnostic message, along with the code 102, appears on the display.

11.3.11 Measured Value

Path: Application ▶ Sensor ▶ Extended setup ▶ Diagnostic settings

Function	Options	Info
ORP Measured Value		
Function	Selection <ul style="list-style-type: none"> • Off • On Factory setting Off	Switches the function on or off
Upper alarm limit	-2000 ... 20000 mV	Diagnostics code and associated message text: 124 Sensor glass
Upper warning limit	-2000 ... 20000 mV	Diagnostics code and associated message text: 125 Sensor glass
Lower warning limit	-2000 ... 20000 mV	Diagnostics code and associated message text: 123 Sensor glass
Lower alarm limit	-2000 ... 20000 mV	Diagnostics code and associated message text: 122 Sensor glass

11.3.12 Pharmaceutical Water

Path: Application ▶ Sensor ▶ Extended setup ▶ Diagnostic settings

Function	Options	Info
Pharmaceutical water		<p>Here you can make settings for monitoring pharmaceutical water in accordance with the United States Pharmacopoeia (USP) or European Pharmacopoeia (EP).</p> <p>The uncompensated conductivity value and the temperature are measured for the limit functions. The measured values are compared against the tables defined in the standards. An alarm is triggered if the limit value is exceeded. Furthermore, you can also set a preliminary alarm (warning limit) which signals undesired operating states before they occur.</p>
Function	Selection <ul style="list-style-type: none"> • Off • EP • USP Factory setting Off	The alarm values are stored in the device in accordance with USP <645> or EP <169> specifications. You define the warning limit as a % of the alarm value.
Off	10.0 ... 99.9 % Factory setting 80.0 %	Diagnostics code and associated message text: 915 USP / EP warning If the value exceeds the USP or EP alarm values saved in the software, diagnostics message 914 USP/ EP alarm is displayed.

11.3.13 Cap Calibrations

Path: Application ▶ Sensor ▶ Extended setup ▶ Diagnostic settings

Function	Options	Info
No. calibrations cap		<p>Not displayed for optical oxygen sensors.</p> <p>The calibration counters in the sensor make a distinction between sensor calibrations and calibrations with the membrane cap currently used. If this cap is replaced, only the (cap) counter is reset.</p>
Function	Selection <ul style="list-style-type: none"> • Off • On Factory setting Off	Specify how many calibrations may be performed with a membrane cap before the cap has to be replaced. The number depends heavily on the process and must be determined individually.
Warning limit	1 ... 1000 Factory setting 6	Diagnostics code and associated message text: 535 Sensor check

11.4 Simulation

You can simulate certain parameters for test purposes:

- Current value
- Measured value
- Temperature

Path: [Diagnostics](#) ▶ [Simulation](#)

Function	Options	Info
Current output		Simulation of an output current.
Simulation	Selection <ul style="list-style-type: none"> • Off • On Factory setting Off	Switch simulation on or off.
Simulation value	3.6... 23 mA	Set current value.
Measured value		Simulation of a measured value.
Simulation	Selection <ul style="list-style-type: none"> • Off • On Factory setting Off	Switch simulation on or off.
Process variable	Dependent on sensor	Select measured variable to be simulated, depending on connected sensor.
Simulation value		Display the simulated measured value in the selected unit.
Temperature		Simulation of temperature.
Simulation	Selection <ul style="list-style-type: none"> • Off • On Factory setting Off	Switch simulation on or off.
Simulation value		Display the simulated temperature value in the selected unit.

11.5 Diagnostic List

Diagnostic Messages

In accordance with Namur specification NE107, the diagnostic messages are characterized by:

- Message number
- Error category (letter in front of the message number)
 - F = (Failure) a malfunction has been detected.
 - C = (Function check), (no error).
Maintenance work is being performed on the device. Wait until the work has been completed.
 - S = (Out of specification), the measuring point is being operated outside its specification.
Operation is still possible. However, you run the risk of increased wear, shorter operating life, or lower measurement accuracy. The cause of the problem is to be found outside the measuring point.
 - M = (Maintenance required), action should be taken as soon as possible.
- Sensor type:
 - P = pH
 - C = conductivity
 - O = oxygen
- Message text

No.	Message	S ¹⁾	D ²⁾	F ³⁾	Sensor type	Configurable	Tests or remedial action
002	Sensor unknown	F	On	On	All	No	• Replace sensor.
004	Sensor defective	F	On	On	All	No	• Replace sensor.
005	Sensor data invalid	F	On	On	All	No	1. Check the firmware compatibility of the sensor and transmitter or load suitable firmware. 2. Set the sensor to the factory settings, disconnect the sensor, and reconnect it. 3. Update transmitter data. 4. Replace sensor.
010	Sensor scanning	F	Off	Off	All	No	• Wait for initialization to be finished.
012	Writing data failed	F	On	On	All	No	1. Repeat write process. 2. Replace sensor.
013	Sensor type wrong	F	On	On	All	No	• Replace sensor, making sure correct sensor type is used.
018	Sensor not ready	F	On	On	All	No	Sensor communication blocked. 1. Sensor fails tag check. Replace. 2. Internal software error. Contact the Service Department.
022	Temperature sensor	F	On	On	All	Yes	Temperature sensor defective. • Replace sensor.
061	Sensor electronic	F	On	On	All	No	Sensor electronics defective • Replace sensor.
062	Sensor connection	F	On	On	All	No	1. Check sensor connection. 2. Contact the Service Department.

¹⁾ Status signal factory setting

²⁾ Diagnostics message factory setting

³⁾ Fault current factory setting

No.	Message	S ¹⁾	D ²⁾	F ³⁾	Sensor type	Configurable	Tests or remedial action
100	Sensor communication	F	On	On	All	No	Sensor not communicating. 1. Check sensor connection. 2. Check sensor connector. 3. Contact the Service Department.
102	Calibration timer	M	On	Off	All	Yes	Calibration interval elapsed. Measurement can still take place. • Calibrate sensor.
104	Calibration validity	M	On	Off	All	Yes	Last calibration no longer valid. Measurement can still take place. • Calibrate sensor.
105	Calibration validity	M	On	Off	All	Yes	Last calibration will lose its validity soon. Measurement can still take place. • Calibrate sensor.
106	Sensor TAG	F	On	On	All	No	Sensor has invalid TAG or TAG group.
107	Calibration active	C	On	Off	All	No	• Wait for calibration to be finished.
108	SIP, CIP, autoclaving	M	On	Off	O	Yes	Specified number of sterilizations will soon be reached. Measurement can still take place. • Replace sensor.
109	Sterilization cap	M	On	Off	O	No	Specified number of sterilizations for the cap is reached. Measurement can still take place. • Replace membrane cap.
111	Operating time cap	M	On	Off	O	No	Hours of operation monitoring. The limit set for the total hours of operation for the cap has been reached. Measurement can still take place. 1. Replace the cap. 2. Change monitoring limit.
118	Sensor glass break.	F	On	Off	P (glass)	Yes	Glass breakage warning, impedance of pH glass too low.
119	Sensor check	M	On	Off	P (glass)	No	Measuring can continue until the alarm (118) occurs. 1. Inspect sensor for hair-line cracks and breakage. 2. Check medium temperature. 3. Replace sensor.
120	Sensor reference	F	On	Off	P (glass)	Yes	Reference warning, impedance of reference too low
121	Sensor reference	M	On	Off	P (glass)	No	Measuring can continue until the alarm (120) occurs. 1. Check reference for clogging/contamination. 2. Clean reference/junction. 3. Replace sensor.

¹⁾ Status signal factory setting

²⁾ Diagnostics message factory setting

³⁾ Fault current factory setting

No.	Message	S ¹⁾	D ²⁾	F ³⁾	Sensor type	Configurable	Tests or remedial action
122	Sensor glass	F	On	Off	P (glass)	Yes	Impedance limit values exceeded/ undershot. Measuring can continue until the alarm (122, 124) occurs.
123	Sensor glass	M	On	Off	P (glass)	Yes	
124	Sensor glass	M	On	Off	P (glass)	Yes	
125	Sensor glass	F	On	Off	P (glass)	Yes	
126	Sensor check	M	On	Off	P (glass)	No	Sensor condition check (SCC), poor sensor condition. Glass membrane fouled or dry, junction blocked. 1. Clean sensor, regenerate. 2. Replace sensor.
127	Sensor check	M	On	Off	P (glass)	No	Sensor condition check (SCC), adequate sensor condition.
128	Sensor leakage	F	On	Off	P (ISFET), O	Yes	Leak current alarm. Defective due to abrasion or damage Damage to the gate (only ISFET). • Replace sensor.
129	Sensor leakage	F	On	Off	P (ISFET), DO	Yes	Leak current warning. Measuring can continue until the alarm occurs.
130	Sensor supply	F	On	Off	P, O	Yes	Poor sensor power supply. 1. Check sensor connection. 2. Replace sensor.
136	Sensor temp. high	S	On	Off	O	No	Temperature outside specification. 1. Check process. 2. Check installation.
141	Polarization	F	On	Off	C	No	Polarization warning. The measured value is corrupted at high conductivity levels. • Use a sensor with a larger cell constant.
142	Sensor signal	F	On	Off	C	No	Reasons: sensor in air, sensor defective. 1. Check installation. 2. Replace sensor.
146	Sensor temperature	S	Off	Off	All	Yes	Temperature outside specification. 1. Check the temperature. 2. Check electrode system. 3. Replace sensor type.
154	Sensor data invalid	M	Off	Off	C	No	Factory calibration is used. • Calibrate.
160	Sensor data invalid	F	On	Off	All	No	No calibration data. Reasons: data deleted. 1. Select other data record. 2. Use factory calibration. 3. Contact the Service Department.

¹⁾ Status signal factory setting

²⁾ Diagnostics message factory setting

³⁾ Fault current factory setting

No.	Message	S ¹⁾	D ²⁾	F ³⁾	Sensor type	Configurable	Tests or remedial action
164	Sensor data invalid	M	Off	Off	C	No	No temperature calibration data. Factory calibration is used. 1. Check process. 2. Check or replace sensor.
168	Polarization	S	On	Off	C (cond.)	No	Polarization warning. The measured value is corrupted at high conductivity levels. • Use a sensor with a larger cell constant.
178	Operating time	M	On	Off	All	No	Operating hours > 15 °C, measurement can still take place. 1. Replace sensor. 2. Change monitoring limit. 3. Disable monitoring.
179	Operating time	M	On	Off	P	No	Operating hours > 300 mV, measurement can still take place. 1. Replace sensor. 2. Change monitoring limit. 3. Disable monitoring.
180	Operating time	M	On	Off	P	No	Operating hours <- 300 mV, measurement can still take place. 1. Replace sensor. 2. Change monitoring limit. 3. Disable monitoring.
183	Operating time	M	On	Off	O (amp.)	No	Operating hours > 10 nA (OOS51D), measurement can still take place. 1. Replace sensor. 2. Change monitoring limit. 3. Disable monitoring.
184	Operating time	M	On	Off	O (amp.)	No	Operating hours > 30 nA (OOS22D), measurement can still take place. 1. Replace sensor. 2. Change monitoring limit. 3. Disable monitoring.
185	Operating time	M	On	Off	O (amp.)	No	Operating hours > 40 nA (OOS51D), measurement can still take place. 1. Replace sensor. 2. Change monitoring limit. 3. Disable monitoring.
186	Operating time	M	On	Off	O (amp.)	No	Operating hours > 160 nA (OOS22D), measurement can still take place. 1. Replace sensor. 2. Change monitoring limit. 3. Disable monitoring.
187	Operating time	M	On	Off	C	No	Operating hours > 80 °C, 100 nS/cm, measurement can still take place. 1. Replace sensor. 2. Change monitoring limit. 3. Disable monitoring.

¹⁾ Status signal factory setting

²⁾ Diagnostics message factory setting

³⁾ Fault current factory setting

No.	Message	S ¹⁾	D ²⁾	F ³⁾	Sensor type	Configurable	Tests or remedial action
189	Operating time	M	On	Off	O	No	Operating hours > 5 °C, measurement can still take place. 1. Replace sensor. 2. Change monitoring limit. 3. Disable monitoring.
191	Operating time	M	On	Off	O	No	Operating hours > 30 °C, measurement can still take place. 1. Replace sensor. 2. Change monitoring limit. 3. Disable monitoring.
192	Operating time	M	On	Off	O	No	Operating hours > 40 °C, measurement can still take place. 1. Replace sensor. 2. Change monitoring limit. 3. Disable monitoring.
193	Operating time	M	On	Off	P, C, O	No	Operating hours > 80 °C, measurement can still take place. 1. Replace sensor. 2. Change monitoring limit. 3. Disable monitoring.
194	Operating time	M	On	Off	P	No	Operating hours > 100 °C, measurement can still take place. 1. Replace sensor. 2. Change monitoring limit. 3. Disable monitoring.
195	Operating time	M	On	Off	C	No	Operating hours > 120 °C, measurement can still take place. 1. Replace sensor. 2. Change monitoring limit. 3. Disable monitoring.
197	Operating time	M	On	Off	C	No	Operating hours > 140 °C, measurement can still take place. 1. Replace sensor. 2. Change monitoring limit. 3. Disable monitoring.
198	Operating time	M	On	Off	C	No	Operating hours > 150 °C, measurement can still take place. 1. Replace sensor. 2. Change monitoring limit. 3. Disable monitoring.
199	Operating time	M	On	Off	All	No	Total operating hours
202	Self-test active	F	On	On	All	No	Self-test active, please wait.
215	Simulation active	C	On	Off	All	No	Simulation active. End simulation by changing to measuring mode.
216	Hold active	C	On	Off	All	No	HOLD active. Output values and channel status are on hold. • Please wait.

¹⁾ Status signal factory setting

²⁾ Diagnostics message factory setting

³⁾ Fault current factory setting

No.	Message	S ¹⁾	D ²⁾	F ³⁾	Sensor type	Configurable	Tests or remedial action
241	Firmware error	F	On	On	All	No	Software error - internal 1. Carry out software update. 2. Replace backplane. 3. Please contact the Service Department and quote the number shown.
243	Firmware error	F	On	On	All	No	Software error - internal 1. Carry out software update. 2. Replace backplane. 3. Please contact the Service Department and quote the number shown.
284	Firmware update	F	On	On	All	No	Firmware update active, please wait.
285	Update error	F	On	On	All	No	Firmware update failed. Possible reasons: Read error, SD card is faulty, incorrect firmware on SD card. 1. Check device settings. 2. Check electronics module type.
373	Temperature of electronics is high	M	On	Off	All	No	Temperature of backplane electronics is high. • Check ambient temperature and energy consumption.
384	Firmware error	F	On	On	All	No	Sensor measuring sequence counter. No measurement signal from sensor. 1. Update software. 2. Contact the Service Department.
408	Calibration aborted	M	Off	Off	P, C, O,	No	Calibration aborted.
411	Upload/download active, please wait	C	On	Off	All	No	Up-/Download active, • please wait.
460	Output undershot	S	On	Off	All	No	Current output undershot. Measured value out of specified current range. Possible reasons: Sensor / sample line in air, air pockets in the fitting, incorrect flow to sensor, sensor / sample line is contaminated. 1. Check sensor. 2. Check application. 3. Clean sensor / sample line.
461	Output overshoot	S	On	Off	All	No	Current output overshoot. Measured value out of specified current range. Possible reasons: Sensor / sample line in air, air pockets in the fitting, incorrect flow to sensor, sensor / sample line is contaminated. 1. Check sensor. 2. Check application. 3. Clean sensor / sample line.

¹⁾ Status signal factory setting

²⁾ Diagnostics message factory setting

³⁾ Fault current factory setting

No.	Message	S ¹⁾	D ²⁾	F ³⁾	Sensor type	Configurable	Tests or remedial action
500	Sensor calibration	M	On	Off	All	No	Calibration aborted, main measured value varies. Reasons: sensor too old, sensor occasionally dry, calibration value not constant. 1. Check sensor. 2. Check calibration solution.
501	Sensor calibration	M	On	Off	All	No	Calibration aborted, temperature measured value varies. Reasons: sensor too old, sensor occasionally dry, temperature of calibration solution not constant. 1. Check sensor. 2. Regulate calibration solution temperature.
505	Sensor calibration	M	On	Off	P, O	No	Max. zero point warning. Measurement can still take place. Possible reasons: sensor old or defective, reference blocked, calibration solution too old or contaminated. 1. Check or replace sensor. 2. Check or replace calibration solution. 3. Repeat calibration.
507	Sensor calibration	M	On	Off	P, O	No	Min. zero point warning. Measurement can still take place. Possible reasons: sensor old or defective, reference blocked, calibration solution too old or contaminated. 1. Check or replace sensor. 2. Check or replace calibration solution. 3. Repeat calibration.
509	Sensor calibration	M	On	Off	P, O	No	Min. slope warning. Measurement can still take place. Possible reasons: sensor old or defective, reference blocked, calibration solution too old or contaminated. 1. Check or replace sensor. 2. Check or replace calibration solution. 3. Repeat calibration.
511	Sensor calibration	M	On	Off	P, O	No	Max. slope warning. Measurement can still take place. Possible reasons: sensor old or defective, reference blocked, calibration solution too old or contaminated. 1. Check or replace sensor. 2. Check or replace calibration solution. 3. Repeat calibration.

¹⁾ Status signal factory setting

²⁾ Diagnostics message factory setting

³⁾ Fault current factory setting

No.	Message	S ¹⁾	D ²⁾	F ³⁾	Sensor type	Configurable	Tests or remedial action
513	Zero warning	M	On	Off	O (amp.)	No	Zero point warning. Measurement can still take place. Possible reasons: sensor old or defective, reference blocked, calibration solution too old or contaminated 1. Check or replace sensor. 2. Check or replace calibration solution. 3. Repeat calibration.
515	Sensor calibration	M	On	Off	P (ISFET)	No	Max. operating point warning. Measurement can still take place. Possible reasons: sensor old or defective, reference blocked, calibration solution too old or contaminated 1. Check or replace sensor. 2. Check or replace calibration solution. 3. Repeat calibration.
517	Sensor calibration	M	On	Off	P (ISFET)	No	Min. operating point warning. Measurement can still take place. Possible reasons: sensor old or defective, reference blocked, calibration solution too old or contaminated 1. Check or replace sensor. 2. Check or replace calibration solution. 3. Repeat calibration.
518	Sensor calibration	M	On	Off	P, O	No	Delta slope warning. Measurement can still take place. Possible reasons: sensor old or defective, reference blocked, calibration solution too old or contaminated 1. Check or replace sensor. 2. Check or replace calibration solution. 3. Repeat calibration.
520	Sensor calibration	M	On	Off	P, O	No	Delta zero point warning. Measurement can still take place. Possible reasons: sensor old or defective, reference blocked, calibration solution too old or contaminated 1. Check or replace sensor. 2. Check or replace calibration solution. 3. Repeat calibration.
522	Sensor calibration	M	On	Off	P (ISFET)	No	Delta operating point warning. Measurement can still take place. Possible reasons: sensor old or defective, reference blocked, calibration solution too old or contaminated 1. Check or replace sensor. 2. Check or replace calibration solution. 3. Repeat calibration.
532	License error	M	On	Off	All	No	License error

¹⁾ Status signal factory setting

²⁾ Diagnostics message factory setting

³⁾ Fault current factory setting

No.	Message	S ¹⁾	D ²⁾	F ³⁾	Sensor type	Configurable	Tests or remedial action
534	Electrolyte warning	M	On	Off	All	No	Electrolyte depletion warning. The configured electrolyte depletion limit has been reached. Measurement is still possible. <ol style="list-style-type: none"> 1. Replace electrolyte and, if necessary, the membrane cap. 2. Reset counter for CAL. 3. Replace electrolyte, or replace sensor cap and electrolyte. 4. Replace sensor.
535	Sensor check	M	On	Off	O (amp.)	No	Specified number of cap calibrations is reached. Measurement can still take place. <ul style="list-style-type: none"> • Replace sensor cap.
550	Process temperature	S	On	Off	C	No	Process temperature above/below concentration table. Possible reasons: process value outside specification, table incomplete. <ul style="list-style-type: none"> • Extend table.
551	Process temperature	S	On	Off	C		
552	Conductivity low	S	On	Off	C	No	Conductivity above/below concentration table. Possible reasons: process value outside specification, table incomplete. <ul style="list-style-type: none"> • Extend table.
553	Conductivity high	S	On	Off	C		
554	Concentration low	S	On	Off	C	No	Process concentration above/below concentration table. Possible reasons: process value outside specification, table incomplete. <ul style="list-style-type: none"> • Extend table.
555	Concentration high	S	On	Off	C		
722	Sensor reference	F	On	On	P	Yes	Alarm: Reference membrane impedance too low. <ol style="list-style-type: none"> 1. Check or replace sensor. 2. Check/correct reference limit value.
723	Sensor reference	M	On	Off	All	Yes	Warning: Reference membrane impedance too low. Can continue measuring until the alarm occurs. <ol style="list-style-type: none"> 1. Check or replace sensor. 2. Check/correct reference limit value.
724	Sensor reference	F	On	On	All	Yes	Alarm: Reference membrane impedance too high. <ol style="list-style-type: none"> 1. Check or replace sensor. 2. Check/correct reference limit value.
725	Sensor reference	M	On	Off	All	Yes	Warning: Reference membrane impedance too high. Can continue measuring until the alarm occurs. <ol style="list-style-type: none"> 1. Check or replace sensor. 2. Check/correct reference limit value.

¹⁾ Status signal factory setting

²⁾ Diagnostics message factory setting

³⁾ Fault current factory setting

No.	Message	S ¹⁾	D ²⁾	F ³⁾	Sensor type	Configurable	Tests or remedial action
734	Calibration quality	M	On	Off	All	No	Min. calibration quality warning. Measurement can still take place. There is a significant change in calibration quality since the last calibration. 1. Repeat calibration. 2. Check sensor and replace if necessary.
740	Sensor defective	F	On	On	C	No	Internal electrode failure. 1. Replace sensor. 2. Contact the Service Department.
832	Temp. range exceeded	S	Off	Off	All	Yes	Outside temperature specification. 1. Check application. 2. Check temperature sensor.
841	Operating range	S	Off	Off	All	Yes	Process value outside operational range. 1. Check application. 2. Check sensor.
842	Process value	S	Off	Off	P	Yes	Process limit value exceeded/undershot. Reasons: sensor in air, air pockets in fitting, incorrect flow to sensor, sensor defective. 1. Change process value. 2. Check electrode system. 3. Change sensor type.
843	Process value	S	Off	Off	P		
904	Process check alarm	F	On	On	All	No	Stagnating measuring signal. Reasons: sensor in air, sensor fouling, incorrect flow to sensor, sensor defective. 1. Check electrode system. 2. Check sensor. 3. Restart the device.
910	Limit switches	S	On	Off		No	Limit switch activated.
914	USP / EP alarm	M	On	Off	C	Yes	USP limit values exceeded. • Check process.
915	USP / EP warning	M	On	Off	C		
942	Process value	S	Off	Off	P	No	Process value high. 1. Do not increase process value. 2. Check electrode system. 3. Change sensor type.
943	Process value	S	Off	Off	P	No	Process value low. 1. Do not decrease process value. 2. Check electrode system. 3. Change sensor type.
987	Calibration required	M	On	On	I, DI	No	Electrode replacement. • Calibrate sensor.

¹⁾ Status signal factory setting

²⁾ Diagnostics message factory setting

³⁾ Fault current factory setting

11.6 Event Logbook

Diagnostics ▶ Diagnostics logbook

Function	Info
Diagnostics code	Diagnostic number and brief text
Time	Time when diagnostic message occurred.
Event	Indicate whether message is going or coming.
Status signal	Error category and fault elimination
Long text	Troubleshooting steps

11.7 Resetting the Measuring Device

Path: System ▶ Device management

Function	Options	Info
Device restart	Press Finish to start the application. Press X to close the wizard without running it and to go back.	Restart and keep all the settings.
Factory settings	Press Finish to start the application. Press X to close the wizard without running it and to go back.	Restart with factory settings. Settings that have not been saved are lost. TAG does not change.

11.8 Device Information

Squawk

Path: System ▶ Device Management ▶ Squawk

Function	Options	Info
Squawk	Selection <ul style="list-style-type: none"> • Off • On Factory setting Off	Squawk is signaled briefly while the connection is established. This allows the device to be located more quickly in large installations.

12 Maintenance

12.1 Remarks

The maintenance of the measuring point comprises:

- Calibration
- Cleaning the compact transmitter, fitting, and sensor
- Checking the cables and connections

⚠ WARNING! Process pressure and temperature, contamination. Risk of serious or fatal injury.

- If the sensor has to be removed during maintenance work, avoid hazards posed by pressure, temperature, and contamination.

NOTICE! Electrostatic discharge (ESD). Risk of damaging the electronic components.

- Take personal protective measures to avoid ESD, such as discharging beforehand at PE or permanent grounding with a wrist strap.

12.2 Maintenance Tasks

12.2.1 Cleaning

NOTICE! Cleaning agents not permitted. Damage to housing surface and optical waveguide.

- Never use concentrated mineral acids or alkaline solutions for cleaning.
- Never use organic cleaners such as acetone, benzyl alcohol, methanol, methylene chloride, tetrahydrofuran, xylene or concentrated glycerol cleaner.

The device is resistant to:

- Ethanol (for a short time)
- Diluted acids (max. 2% HCl)
- Diluted bases (max. 3% NaOH)
- Soap-based household cleaners
- Dishwashing liquid

12.2.2 Calibration

To calibrate the sensor, remove it from the medium and calibrate it in the laboratory. Since Memosens sensors save the data, you can always work with precalibrated sensors and do not have to stop monitoring the process to perform a calibration.

Path: [Guidance](#) ▶ [Calibration](#)

01. Select calibration type.
02. Follow the instructions of the software.
03. Return the sensor to the medium.

Result

- ✓ This deactivates the hold and the system starts measuring again.

13 Repair

13.1 General Notes

13.2 Return

The product must be returned if repairs or a factory calibration are required, or if the wrong product was ordered or delivered.

To ensure safe, professional, and swift product returns, please contact your local Sales Center for information on the procedure to be followed and general conditions.

13.3 Disposal

The device contains electronic components. It must therefore be disposed of in accordance with regulations on the disposal of electronic waste.

- Observe the local regulations.

14 Specifications

Input	Multiparameter Memosens input for pH, ORP sensors and ISFET, conductivity and oxygen sensors		
Measured value transmission	4 ... 20 mA HART		
Measuring range	See documentation for connected sensor		
pH, ORP display range ¹⁾	pH value:	-2.00 ... 16.00	
	pH raw value:	-2000 ... 2000 mV	
	Glass impedance:	0.0 ... 200,000.0 MΩ	
	Reference impedance:	0.0 ... 2,000,000.0 Ω	
	ORP:	-2000 mV	
	ORP %:	-3,000.0 ... 3,000.0 %	
	rH:	0.0 ... 70.0 rH	
	Temperature:	-50.0 ... 150.0 °C / -58.0 ... 302.0 °F / 223.2 ... 423.2 K	
Conductivity display range ¹⁾	Conductivity:	0.000 ... 2,000 mS/cm / 0.000 ... 2,000,000 μS/cm 0.000 ... 2.000 S/cm / 0.000 ... 200,000,000 μS/cm 0.000 ... 20,000 mS/m / 0.000 ... 200.0 S/m	
	Resistance:	0.000 ... 200,000,000 Ωcm	
	Raw value (uncompensated conductivity):	0.000 ... 2,000 mS/cm / 0.000 ... 2,000,000 μS/cm 0.000 ... 2.000 S/cm / 0.000 ... 200,000,000 μS/cm 0.000 ... 20,000 mS/m / 0.000 ... 200.0 S/m	
	Temperature:	0.0 ... 100.0 °C / 32.0 ... 212.0 °F / 223.2 ... 523.2 K	
	Oxygen display range ¹⁾	Partial pressure:	0.00 ... 400.0 hPa
		Concentration in liquids:	0.00 ... 20.00 mg/l / -20.00 ... 120,000.00 μg/l -0.02 ... 120.00 ppm / -20.00 ... 120,000.00 ppb
Concentration in gas phase:		0.00 ... 20.00 %Vol -200.00 ... 2,000,000.00 ppmVol	
Raw value nA:		0.00 ... 12,000.00 nA	
Temperature:		-50.0 ... 250.0 °C / -58.0 ... 482.0 °F / 223.2 ... 523.2 K	
pH/ORP sensor standardization Operating modes	pH calibration:	1-point calibration 2-point calibration Calibration by sampling	
	ORP calibration:	1-point calibration (mV) 2-point calibration (%)	
pH buffer sets	Endress+Hauser: Ingold/Mettler: DIN 19266: DIN 19267: Merck/Riedel: Hamilton:	2.00 / 4.00 / 7.00 / (9.00) / 9.22 / 10.00 / 12.00 2.00 / 4.01 / 7.00 / 9.21 1.68 / 4.01 / 6.86 / 9.18 1.09 / 4.65 / 6.79 / 9.23 / 12.75 2.00 / 4.01 / 6.98 / 8.95 / 12.00 1.09 / 1.68 / 2.00 / 3.06 / 4.01 / 5.00 / 6.00 7.00 / 8.00 / 9.21 / 10.01 / 11.00 / 12.00	
Conductivity sensor standardization Operating modes	Cell constant		

¹⁾ Display ranges may vary depending on the sensor type. Refer to the documentation for the connected sensor.

Oxygen sensor standardization	Slope
Operating modes	Zero point Electrolyte Save electrolyte replacement Save membrane cap
Calibration timer	0000 ... 10,000 h (hours)
Measurement error	$\pm 50 \mu\text{A}$ at 20 mA T = 25 °C / 77 °F $\pm 20 \mu\text{A}$ at 4 mA T = 25 °C / 77 °F Temperature drift: Max. permitted drift of current output: 1.5 $\mu\text{A/K}$
Response time of current output	t ₉₀ = max. 500 ms for a jump from 0 to 20 mA
Resolution of current output	< 5 μA
Time	The date and time function runs only while the device is supplied with power. When power supply is disrupted, the clock will be reset to default. Start time: Date: 1/1/1970 Time: 0:00 hrs
Alarm indication	Green/red LED (depending on alarm settings)
HART communication	Digital transmission of device identification, measured values, status and messages, parameter setting, calibration
pH calibration data	Date, time, mode (calibration method), number of calibrations, zero, slope, isothermal point, buffer 1/2, delta zero, delta slope, serial number of calibration unit (device serial number)
ORP calibration data	Date, time, mode (calibration method), number of calibrations, offset, buffer 1, delta offset, serial number of calibration unit (device serial number)
Conductivity calibration data	Date, time, mode (calibration method), number of calibrations, cell constant, delta cell constant, conductivity reference value, temperature, serial number of calibration unit (device serial number)
Oxygen calibration data	Date, time, device serial number, number of calibrations, mode (calibration method), zero, delta zero, slope, delta slope
Diagnostics	
Diagnostic information Memosens sensor	Glass impedance, slope, delta slope, zero, delta zero, max. operating hours, sterilizations, sterilizations of cap, sensor condition, pharma water, etc. (specifications varying depending on the sensor type)
Diagnostic information MemoTrans	Alarm delay during sensor replacement Diagnostic behavior (maintenance/alarm) Fault current LED indication acc. to NAMUR status signal Status signal acc. to NE 107
EMC	EN 61326-1, EN 61326-2-5, EN 301489-17, EN 61326-2-3, EN 301489-1, NAMUR NE 21
Electrical safety	EN 61010-1
RoHS conformity	2011/65/EU (L174/88)

Nominal Operating Conditions

Ambient temperature	-20 ... 85 °C / -4 ... 185 °F
Transport / storage temperature	-40 ... 85 °C / -40 ... 185 °F
Process temperature	Fitting in measuring position: T(process) = max. 100 °C / 212 °F, continuous operation T(ambient) = max. 60 °C / 140 °F, continuous operation Fitting in service position T(process) = max. 145 °C / 293 °F, continuous operation T(ambient) = max. 60 °C / 140 °F, continuous operation
Relative humidity	5 ... 95 % not condensing
Max. altitude above MSL	< 2000 m / < 6562 ft.
Output	4 ... 20 mA current loop floating, protected against inverse polarity
Linearization/transmission behavior	Linear
Supply voltage	12.6 ... 30 V DC (with a fault current > 20 mA) 14 ... 30 V DC (with a fault current < 4 mA)
Surge protection	IEC 61 000-4-4 and IEC 61 000-4-5, ± 1 kV each
Signal on alarm	3.6 ... 23 mA
Connection	2-wire cable 4 ... 20 mA positive: blue 4 ... 20 mA negative: white
Housing	PEEK, color: light gray, RAL 7035
Memosens closure	PEEK, color: black
Cable	TPE, color: black, Ø approx. 5 mm
Optical waveguide	PC; color: transparent
Cable length	3 m / 10 ft; 7 m / 23 ft; 15 m / 49 ft
Impact loads	The product is designed for mechanical impact loads of 1 J (IK06) as per the requirements of EN 61010-1.
Dimensions	See dimension drawing
Protection	IP67, IP68, NEMA 6
Weight	MemoTrans: with 3 m / 10 ft cable approx. 190 g / 7 oz with 7 m / 23 ft cable approx. 380 g / 13 oz with 15 m / 49 ft cable approx. 760 g / 27 oz
Connections	Terminals, conductor cross-section max. 2.5 mm ²
Simulation	Specific parameters can be simulated for test purposes: Current, measured value, or temperature

15 Power Supply

Supply voltage

12.6 ... 30 V DC (with setting fault current > 20 mA)

14 ... 30 V DC (with setting fault current < 4 mA)

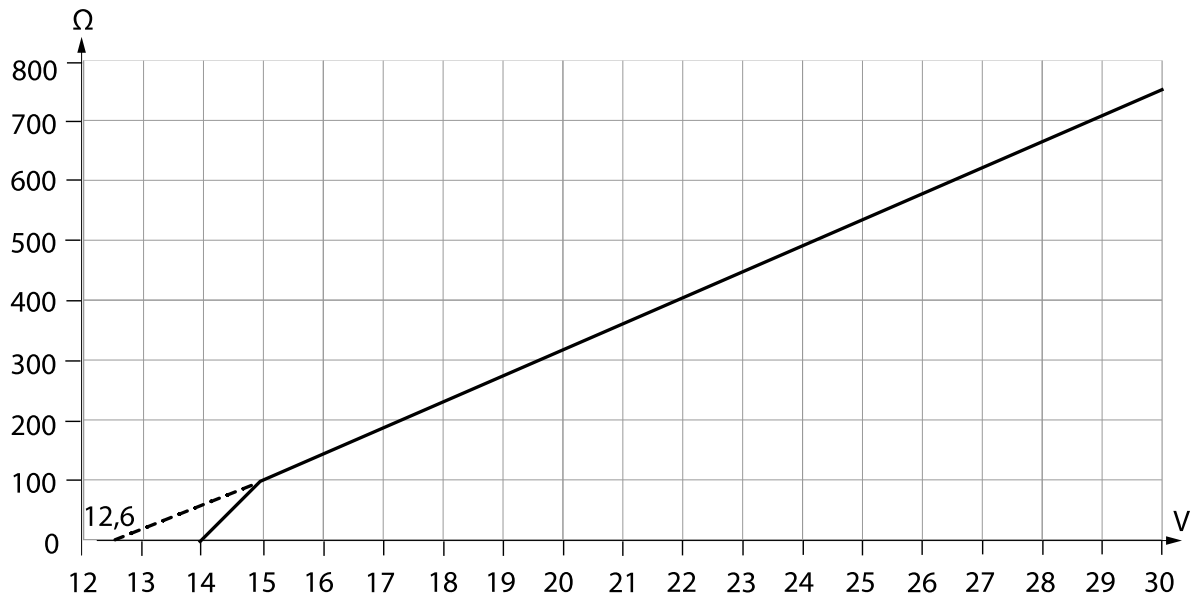

The lower voltage value in each case applies only to a load resistance of 0 Ohm.

NOTICE! The device does not have a power switch.

- At the supply point, the power supply must be isolated from dangerous live cables by double or reinforced insulation in the case of devices with a 24 V power supply.

Index

A

Ambient temperature	51
Approvals	8

C

Calibration	47
Calibration settings	18
Calibration, calibration method	25
Cap calibrations	34
CE mark	8
Certificates	8
Cleaning	47
Commissioning	13
Configuration	15
Connection establishment	46
Connection, electrical	10

D

Date	15
Delta slope	29
Delta zero point	31
Device information	46
Device restart	46
Diagnostic list	36
Diagnostics	26
Diagnostics logbook	46
Dimension drawings	9
Dimensions	9
Display configuration	22
Disposal	48

E

Electrical connection	10
Error messages	36
Event logbook	46

F

Function check	13
----------------	----

H

HART	12
HART, configuration	20
Hold, configuration	21

I

Impedance monitoring	27
Incoming acceptance	8
Installation	9
Installation and function check	13
Installation check	13
Intended use	5
Introductory safety chapter	2

L

LED display	14
Logbook	46

M

Maintenance	47
Measuring parameters	7
Medium compensation	24
Messages	36

N

Nameplate	8
Nominal operating conditions	51
Notes on safety information	2

O

Occupational safety	5
Operating hours	31
Operating menu	11
Operating point	30
Operation	23
Operational safety	6
Overview of menus	11

P

Package contents	8
Personnel requirements	5
Pharmaceutical water	34
Post-connection check	10
Power supply	52
Process monitoring	33
Product description	7
Product design	7
Protection	51

Q

Qualified personnel	5
---------------------	---

R

Repair	48
Reset	46
Return	48

S

Safety Instructions	2, 5
SCC	33
Sensor condition check	33
Simulation	35
Specifications	49
Squawk	46
Supplemental directives	2
Supply voltage	51
Surge protection	51
System integration	12
System settings	15

T

Time	15
Troubleshooting	26

U

Use, intended	5
---------------	---

W

Warnings	2
----------	---

Notes



Knick
Elektronische Messgeräte
GmbH & Co. KG

Headquarters

Beuckestraße 22 • 14163 Berlin
Germany
Phone: +49 30 80191-0
Fax: +49 30 80191-200
info@knick.de
www.knick.de

Local Contacts

www.knick-international.com

Translation of the original instructions
Copyright 2022 • Subject to change
Version 2 • This document was published on April 05, 2022.
The latest documents are available for download on our
website under the corresponding product description.

TA-MT201N-BA-multi-KNEN02



099576